

Contents	1-8
Fluid Nozzle Upgrade Chart	2
Air Cap CFM Rating & Spray Pattern	3
IQ™/Power-Pack™ Performance Settings....	4
IQ™ Top-Load Performance Settings	5
Paint Material & Fluid Tip Chart	6
High Pressure to Low Pressure Conversion Chart	7

FLUID NOZZLE INFORMATION

Mattson Spray Equipment has made a revision to the fluid tips and needles. The modification to the application source was made to accommodate the industry's material changes.

FLUID TIPS and NEEDLES MUST BE ORDERED TOGETHER. THE NEW FLUID TIPS and NEEDLES ARE NOT INTERCHANGEABLE WITH PREVIOUS FLUID TIPS and NEEDLES.

NEW FLUID TIPS DO NOT USE FLUID TIP SEAL #40104. NEW NEEDLE HAS A BLACK BALL STUD.



FLUID TIPS ONLY <i>(NEW fluid tip does not need Fluid Tip Seal #40104)</i>			<i>Kit includes 1-NEW fluid tip, 1-NEW needle assembly</i>	
FLUID TIP SIZE	PREVIOUS FLUID TIP PART #	NEW FLUID TIP PART #	NEW UPGRADE KIT	NEW UPGRADE KIT with HIGH PRESSURE SEAL
.028"	-	#81189	-	-
.032"	#30053	#81513	#7082	#7075
.040"	#30063	#81514	#7083	#7076
.043"	#81197	#82016	#7084	#7077
.050"	#30024	#82017	-	#7078
.060"	#30059	#82018	-	#7079
.070"	#30071	#82019	-	#7080
.086"	#40086	#82020	-	#7081

NEEDLE ASSEMBLIES <i>(NEW needle has a Black Ball Stud)</i>			<i>Kit includes 1-NEW fluid tip, 1-NEW needle assembly</i>	
NEEDLE ASSEMBLY for FLUID TIP SIZE	PREVIOUS NEEDLE ASSEMBLY #	NEW NEEDLE ASSEMBLY PART #	NEW UPGRADE KIT	NEW UPGRADE KIT with HIGH PRESSURE SEAL
.032"	#81025 #70116 w/high pressure seal	#82103 w/high pressure seal	#7082	#7075
.040"	#81025 #70116 w/high pressure seal	#82103 w/high pressure seal	#7083	#7076
.043"	#81025 #70116 w/high pressure seal	#82103 w/high pressure seal	#7084	#7077
.050"	#81025 #70116 w/high pressure seal	#82103 w/high pressure seal	-	#7078
.060"	#70136 w/high pressure seal	#82104 w/high pressure seal	-	#7079
.070"	#70136 w/high pressure seal	#82104 w/high pressure seal	-	#7080
.086"	#70136 w/high pressure seal	#82104 w/high pressure seal	-	#7081

NEEDLES ONLY <i>(NEW needle has a Black Ball Stud)</i>			<i>Kit includes 1-NEW fluid tip, 1-NEW needle assembly</i>	
NEEDLE (ONLY) for FLUID TIP	PREVIOUS NEEDLE (ONLY) PART #	NEW NEEDLE (ONLY) PART #	NEW UPGRADE KIT	NEW UPGRADE KIT with HIGH PRESSURE SEAL
.032"	#70000	#82105	#7082	#7075
.040"	#70000	#82105	#7083	#7076
.043"	#70000	#82105	#7084	#7077
.050"	#70000	#82105	-	#7078
.060"	#70001	#82106	-	#7079
.070"	#70001	#82106	-	#7080
.086"	#70001	#82106	-	#7081

FLUID NOZZLE INFORMATION

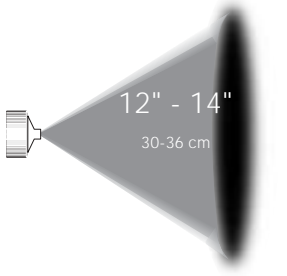
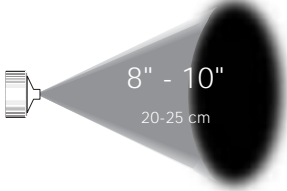
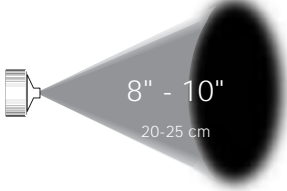
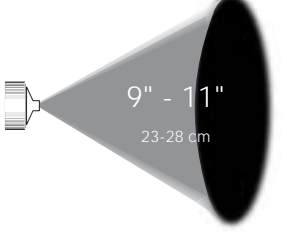
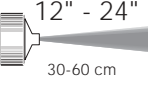
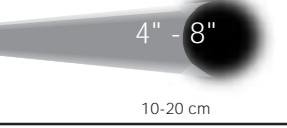
Air Cap CFM Rating & Spray Pattern Chart

Air Cap Type	Part Number	Material Type	3 PSI	5 PSI	Gun Distance	Approx. Fan Size
GuideRing™ w/Black Ring w/Gold Ring w/Silver Ring	7042 7043 7047	Full Range	11 CFM 306 L/min	15 CFM 417 L/min	6" - 8" 15-20 cm	 12" - 14" 30-36 cm
AIR-MISER™ w/Blue Ring	7002	Base & Clear-Coat Low to Med. Solids 250 L/min	9 CFM 333 L/min	12 CFM	8" - 10"	 8" - 10" 20-25 cm
SUPER AIR-MISER™ w/Blue Ring	7003	Base & Clear-Coat Low to Med. Solids 222 L/min	8 CFM 306 L/min	11 CFM	10" - 12" 25-30 cm	 8" - 10" 20-25 cm
HO™ High Output w/Red Ring	7008	Primer & Sealer Med. to High Solids 333 L/min	12 CFM 444 L/min	16 CFM	6" - 8" 15-20 cm	 9" - 11" 23-28 cm
Round Pattern w/Silver Ring	7048	Full Range Special Applications	3 CFM 83 L/min	5 CFM 139 L/min	 12" - 24" 30-60 cm	 4" - 8" 10-20 cm
Small Pattern AIR-MISER™ w/Blue Ring	7090	Full Range Special Applications	8 CFM 222 L/min	11 CFM 306 L/min	6" - 8" 15-20 cm	 2" - 4" 5-10 cm

NOTE: **Selectable Air Caps** feature positive stop switching from vertical to round spray patterns with 1/4-turn of the air cap. Available in GuideRing™, AIR-MISER™ and HO™ High Output. Refer to above chart for air cap spray patterns.

FLUID NOZZLE INFORMATION

IQ™/Power-Pack™ Performance Settings Chart

Material Type* (Ready-to-Spray)	Fluid Tip Size	Cup PSI (bar)	Air Cap PSI** (bar)	
			AIR-MISER™ (blue)	HO™ (red)
UNDERCOATS				
Lacquer Primer Surfacer	.032" (.8 mm) .040" (1.0 mm) .043" [†] (1.1 mm)	5-6 (.34-.41)	3-4 (.2-.27)	3-4 (.2-.27)
2-Component Primer Surfacer	.032" (.8 mm) .040" (1.0 mm) .043" [†] (1.1 mm)	5-9 (.34-.61)	4-5 (.27-.34)	3-4 (.2-.27)
Primer Sealer	.032" (.8 mm) .040" [†] (1.0 mm)	5-6 (.34-.41)	3-4 (.2-.27)	3-5 (.2-.34) 4-5 (.27-.34)
COLOR SYSTEMS				
Acrylic Lacquer	.032" (.8 mm) .040" [†] (1.0 mm)	5 (.34)	3-4 (.2-.27)	3-4 (.2-.27)
Acrylic/Synthetic Enamels	.032" (.8 mm) .040" [†] (1.0 mm)	5-8 (.34-.54)	6-9 (.41-.61)	6-9 (.41-.61)
Acrylic Urethane	.032" (.8 mm) .040" [†] (1.0 mm)	5 (.34) 6-7 (.41-.48)	3-4 (.2-.27)	3-4 (.2-.27) 3-5 (.2-.34)
Base Coat	.032" (.8 mm)	5 (.34)	3-4 (.2-.27)	Not Recommended
Polyurethane	.032" (.8 mm) .040" [†] (1.0 mm)	5-6 (.34-.41) 6-7 (.41-.48)	3-5 (.2-.34)	3-5 (.2-.34) 4-6 (.27-.41)
Low V.O.C.	.032" (.8 mm) .040" [†] (1.0 mm)	6-8 (.41-.54)	6-9 (.41-.61)	6-9 (.41-.61)
Waterborne	.032" (.8 mm)	4-5 (.27-.34)	4-5 (.27-.34)	5-6 (.34-.41)
CLEAR COATS				
Acrylic Lacquer	.032" (.8 mm) .040" [†] (1.0 mm)	5 (.34)	3-4 (.2-.27)	3-4 (.2-.27)
Acrylic Urethane	.032" (.8 mm) .040" [†] (1.0 mm)	5 (.34) 5-7 (.34-.48)	4-5 (.27-.34)	5-6 (.34-.41)
High-Solids Urethane	.032" (.8 mm) .040" (1.0 mm) .043" [†] (1.1 mm)	6-10 (.41-.68)	6-8 (.41-.54)	6-9 (.41-.61)

* Always follow paint manufacturer's ratios for reduction and catalyzation. Use a viscosity cup when possible.

** Calibrate your shop air system's adjustable regulator with the Calibration Gauge included as part of the Power-Pack.

† Optional .040 and .043 fluid tips are available for use with high-solids material.
We do not recommend the .040 fluid tip or HO air cap for application of base coats.

TO ACHIEVE MAXIMUM FLOW-OUT WITHOUT ORANGE PEEL, USE THE NEXT SLOWER SOLVENT TEMPERATURE ESPECIALLY IN HIGH VOLUME PAINT BOOTHS AND HIGH TEMPERATURES.

NOTE: CHANGING THE AIR CAP AFFECTS AIR CAP PSI. REMEMBER TO ADJUST THE PRESSURE WHEN SWITCHING THE AIR CAPS.

FLUID NOZZLE INFORMATION

IQ™ Top-Load Performance Settings Chart

Paint Material Type	Fluid Tip Size & Air Cap PSI (bar)		
	.032" .8 mm	.040" 1.0 mm	.043" 1.1 mm
UNDERCOATS			
Lacquer Primer Surfacer			3-4 (.2-.27)
2-Component Primer Surfacer			3-5 (.2-.34)
Primer Sealer	3-5 (.2-.34)	3-5 (.2-.34)	
Epoxy		3-5 (.2-.34)	
COLOR SYSTEMS			
Acrylic Lacquer	3-4 (.2-.27)		
Acrylic/Synthetic Enamels		6-7 (.41-.48)	
Acrylic Urethane	4-5 (.27-.34)	5-6 (.34-.41)	
Base Coat	3-5 (.2-.34)		
Polyurethane	4-6 (.27-.41)	6-7 (.41-.48)	
Low V.O.C.	6-7 (.41-.48)	7-8 (.48-.54)	
Waterborne	4-5 (.27-.34)	5-6 (.34-.41)	
CLEAR COATS			
Acrylic Lacquer	3-4 (.2-.27)	4-5 (.27-.34)	
Acrylic Urethane	4-5 (.27-.34)	5-6 (.34-.41)	
High Solids Urethane		6-7 (.41-.48)	7-8 (.48-.54)

To achieve maximum flow-out without orange peel, use the next slower solvent temperature especially in high volume paint booths and in high temperatures.

Apply clear coats and acrylic enamels in two **full** wet coats. Medium wet coats do not contain enough material for proper flow-out, giving an orange peel appearance.

For the best possible atomization, start with a smaller fluid tip size. For increased fluid delivery and production speed, increase fluid tip size.

As fluid tip size increases, atomizing air cap psi may need to be increased.

Always follow the paint manufacturer's ratios for reduction and catalyzation. Use a viscosity cup whenever possible.

IQ™ TOP-LOAD PERFORMANCE NOTES:

1. If the gun's air cap gauge does not maintain your pressure setting, your shop air system is not maintaining the air caps CFM requirements.
2. When changing air caps, the air cap pressure setting may require adjustment for best results.
3. For maximum fluid flow, the TotalFlow® knob should always be set at the full open position.
4. To get maximum leveling and flow-out with heavy-bodied materials, use the full open fan setting, full open fluid knob position, and the lowest air cap pressure which gives good atomization.
5. For increased application rates with heavy-bodied materials, a separate cup pressure regulator is available to pressurize the cup independent of the air cap setting. Contact your Mattson distributor for information.

FLUID NOZZLE INFORMATION

Paint Material & Fluid Tip Chart

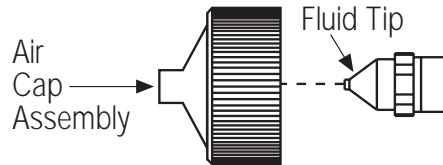

Paint Material Type	Part # & Fluid Tip Size							
	81189 .028 (.7mm)	81513 .032" (.8mm)	81514 .040" (1.0mm)	82016 .043" (1.1mm)	82017 .050" (1.3mm)	82018 .060" (1.5mm)	82019 .070" (1.8mm)	82020 .086" (2.1mm)
UNDERCOATS								
Lacquer Primer Surfacer			✓	✓				
2-Component Primer Surfacer			✓	✓				
Primer Sealer		✓	✓					
Epoxy			✓					
COLOR SYSTEMS								
Acrylic Lacquer	✓	✓						
Acrylic/Synthetic Enamels		✓	✓					
Acrylic Urethane		✓	✓					
Base Coat	✓	✓						
Polyurethane		✓	✓					
Low V.O.C.		✓	✓					
Waterborne		✓	✓		✓	✓	✓	
Varnish	✓	✓						
SPECIAL APPLICATIONS								
High Solids Urethane		✓	✓	✓				
Polyester/Gel Coat					✓	✓	✓	✓
Contact Cement/Glue		✓	✓	✓	✓	✓	✓	
Teflon®		✓						

To achieve maximum flow-out and reduce orange peel, use the next slower solvent temperature especially in high volume paint booths and high temperatures.

For best possible atomization, start with a smaller fluid tip size. For increased fluid delivery and production

speed, increase fluid tip size. As fluid tip size increases, atomizing air cap PSI may need to be increased.

Always follow paint manufacturer's ratios for reduction and catalyzation. Use a viscosity cup when possible.

FLUID NOZZLE INFORMATION

High Pressure to Low Pressure Conversion Chart

The following chart provides the necessary pressure (PSI) requirements at the regulator to obtain a desired air cap pressure. Conversions are provided for all Atom-miser® air cap types.

The results listed in the chart were obtained with a Mattson 5050 Filter Regulator, 2 Milton Quick Connect Couplers and 30 feet of 3/8" ID B.F. Goodrich air hose. The gun was adjusted to full fluid and full fan settings.

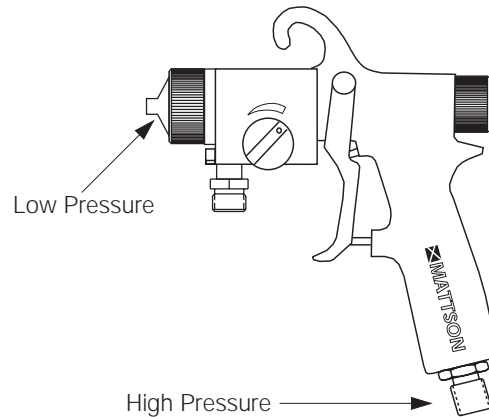

Desired Air Cap PSI (bar)	Required Air Inlet PSI (bar)				
	Round Air Cap	AIR-MISER™ Air Cap	High Output Air Cap	GuideRing™ Air Cap	65 Offset Air Cap
2 PSI (.14)	7 (.5)	18 (1.2)	25 (1.7)	32 (2.2)	18 (1.2)
3 PSI (.2)	11 (.8)	25 (1.7)	32 (2.2)	39 (2.6)	25 (1.7)
4 PSI (.27)	14 (1.0)	30 (2.0)	40 (2.7)	47 (3.2)	30 (2.0)
5 PSI (.34)	16 (1.1)	36 (2.4)	47 (3.2)	55 (3.7)	36 (2.4)
6 PSI (.41)	19 (1.3)	40 (2.7)	56 (3.8)	63 (4.3)	40 (2.7)
7 PSI (.48)	21 (1.4)	45 (3.1)	62 (4.2)	70 (4.8)	45 (3.1)
8 PSI (.54)	24 (1.6)	50 (3.4)	68 (4.6)	77 (5.2)	50 (3.4)
9 PSI (.61)	26 (1.8)	54 (3.7)	75 (5.1)	83 (5.6)	54 (3.7)
10 PSI (.7)	28 (1.9)	58 (3.9)	80 (5.4)	80 (5.4)	58 (3.9)

NOTE: Use of a 5/16" ID hose, a hose longer than 30 feet, or additional quick connects will result in higher values at the 5050 Regulator to achieve the same air cap readings.

The *Pressure Calibration Gauge* (Part #81415) is the **best** way to determine exact regulator settings on your Mattson system. The Pressure Calibration Gauge actually reads the pressure at the air cap dynamically (as the spray gun is working) and accounts for all the variables present in your air delivery system.